

SPECIFICATION		
TOWING CAPACITY	17000 lbs	7700 Kg
TRACTION	4-Wheel drive	
TRACTION WHEELS	10"x3" (25x7cm) Pneumatic	
BATTERIES	6 x 12 volts deep cycle, Group 40, 40-50 amps hour 7 3/4"x6 5/8"x6 7/8" (20x17x19cm) Not included	
BATTERY CHARGER	4 amps, 115/230v, included	
LIFT	300 Watts. Telescopic	
JACK STROKE	4"	102 mm
BRAKES	Triggered when joystick throttle is released	
SHIPPING SIZE	72"x48"x25"	183x121x64cm
SHIPPING WEIGHT	974 lbs	443 Kg
WEIGHT (WITH BATTERY)	744 lbs	338 Kg
SHIPPED FULLY ASSEMBLED		

ROTATION OF AT46 FOR EASY INSERTION IN CHALLENGING SPACE.

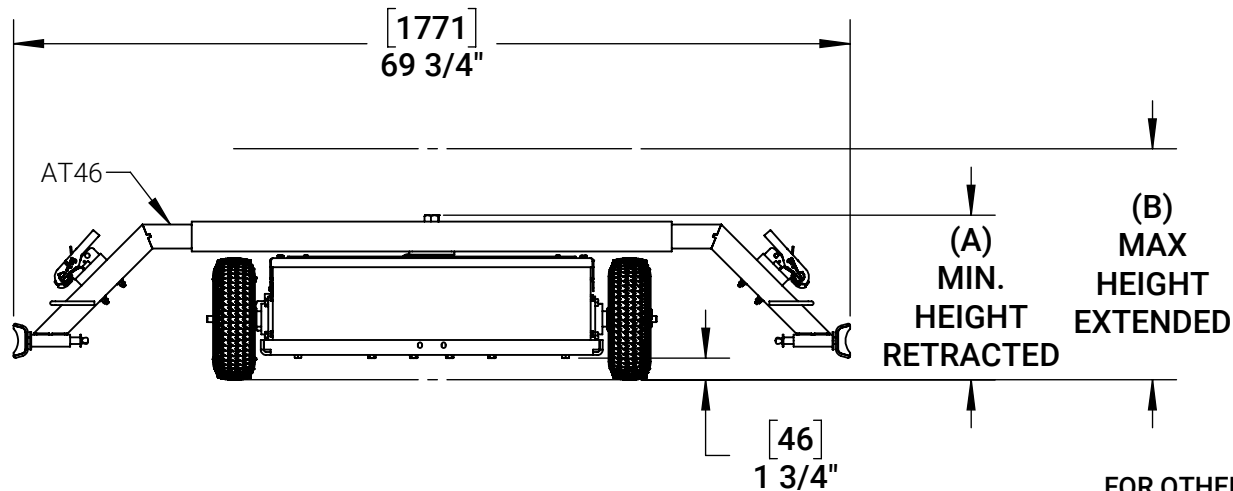

	SHORT HEAD (STANDARD)	LONG HEAD (OPTION)
A	13 3/4" [350 mm]	15 1/8" [385 mm]
B	19 1/4" [489 mm]	21 1/8" [536 mm]

FOR OTHER SPECIAL CONFIGURATIONS CONTACT HELITOWCART

PROPRIETARY AND CONFIDENTIAL

THE INFORMATION CONTAINED IN THIS DRAWING IS THE SOLE PROPERTY OF HELITOWCART Inc. ANY REPRODUCTION IN PART OR AS A WHOLE WITHOUT THE WRITTEN PERMISSION OF HELITOWCART Inc. IS PROHIBITED.



HELITOWCART.COM
INFO@HELITOWCART.COM
+1.418.561.4512

V610

UNIT : [mm]
in

Print Date: 2020-10-15

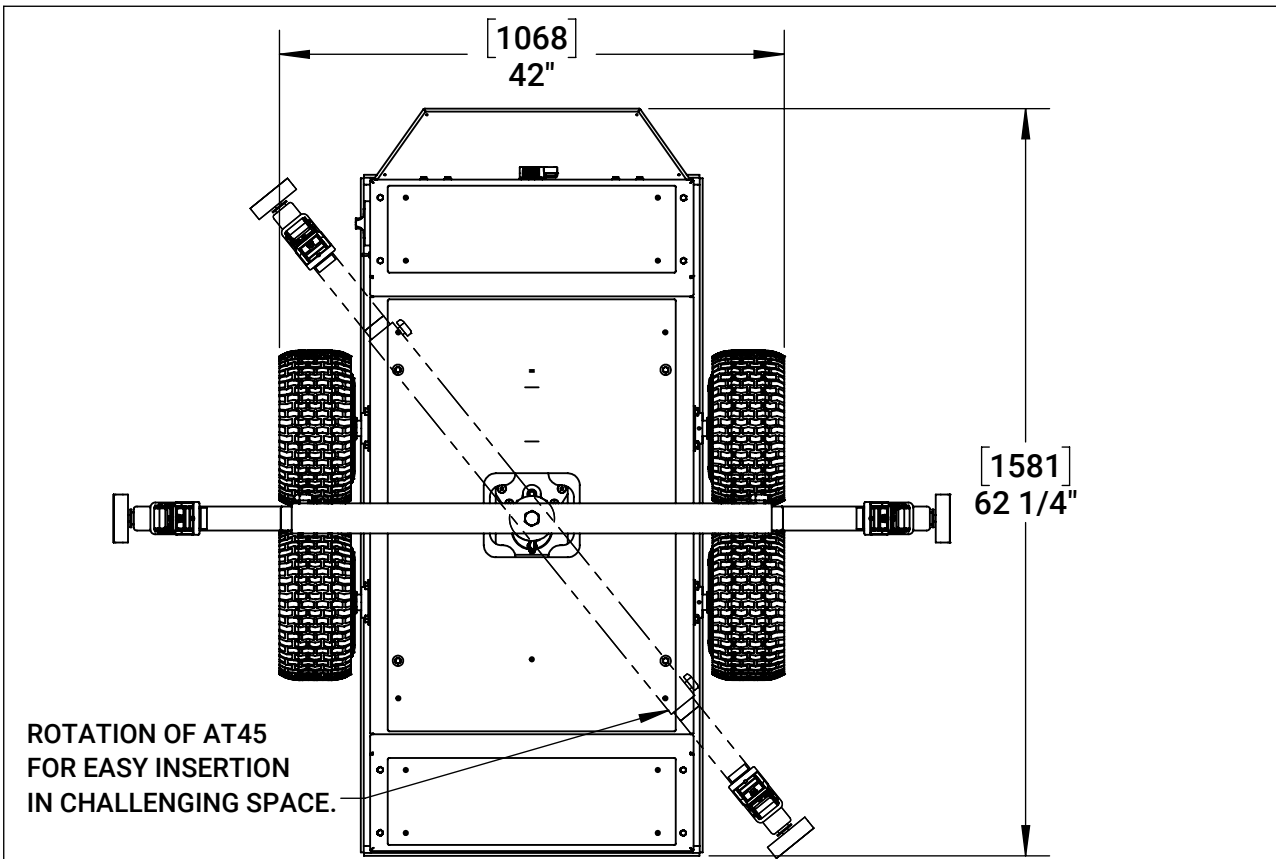

SPECIFICATION		
TOWING CAPACITY	17000 lbs	7700 Kg
TRACTION	4-Wheel drive	
TRACTION WHEELS	13"x6" (33x15cm) Pneumatic	
BATTERIES	6 x 12 volts deep cycle, Group 40, 40-50 amps hour 7 3/4"x6 5/8"x6 7/8" (20x17x19cm) Not included	
BATTERY CHARGER	4 amps, 115/230v, included	
LIFT	300 Watts. Telescopic	
JACK STROKE	4"	102 mm
BRAKES	Triggered when joystick throttle is released	
SHIPPING SIZE	72"x48"x25"	183x121x64cm
SHIPPING WEIGHT	974 lbs	443 Kg
WEIGHT (WITH BATTERY)	744 lbs	338 Kg
SHIPPED FULLY ASSEMBLED		

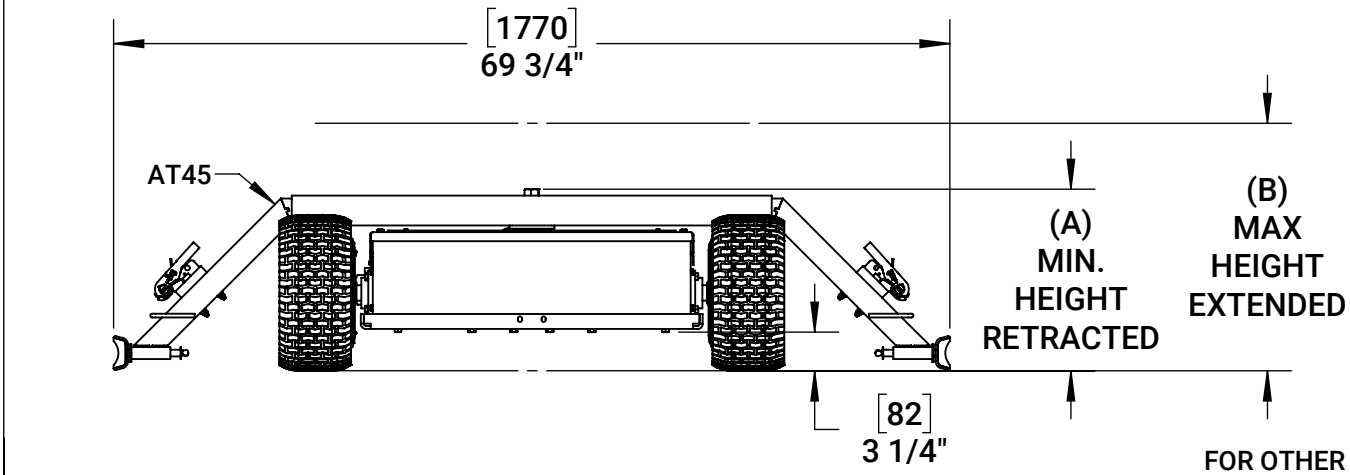

	SHORT HEAD (STANDARD)	LONG HEAD (OPTION)
A	15 1/8" [384 mm]	16 1/2" [420 mm]
B	20 5/8" [524 mm]	22 1/2" [572 mm]

FOR OTHER SPECIAL CONFIGURATIONS CONTACT HELITOWCART

PROPRIETARY AND CONFIDENTIAL
 THE INFORMATION CONTAINED IN THIS DRAWING IS THE SOLE PROPERTY OF HELITOWCART Inc. ANY REPRODUCTION IN PART OR AS A WHOLE WITHOUT THE WRITTEN PERMISSION OF HELITOWCART Inc. IS PROHIBITED.



HELITOWCART.COM
 INFO@HELITOWCART.COM
 +1.418.561.4512

V614

UNIT : [mm]
 in
 Print Date: 2020-10-15

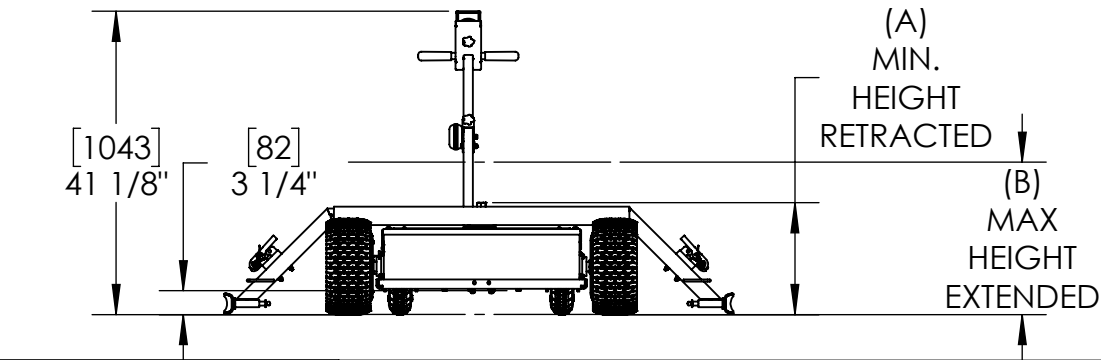
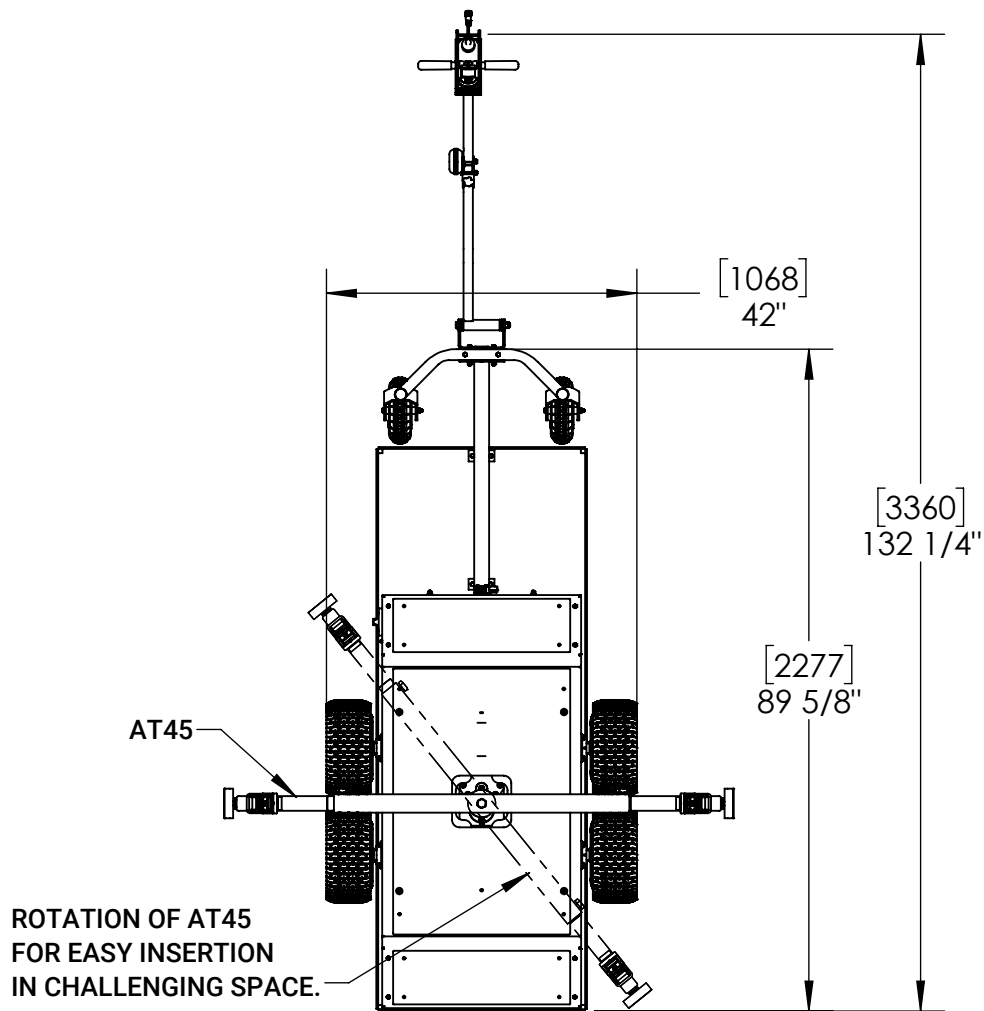

SPECIFICATION

TOWING CAPACITY	17000 lbs	7700 Kg
TRACTION	4-Wheel drive	
TRACTION WHEELS	13"x6" (33x15cm) Pneumatic	
BATTERIES	6 x 12 volts deep cycle, Group 40, 40-50 amps hour 7 3/4"x6 5/8"x6 7/8" (20x17x19cm) Not included	
BATTERY CHARGER	4 amps, 115/230v, included	
LIFT	300 Watts. Telescopic	
JACK STROKE	4"	102 mm
BRAKES	Triggered when joystick throttle is released	
SHIPPING SIZE	87"x48"x25"	220x121x64cm
SHIPPING WEIGHT	1129 lbs	513 Kg
WEIGHT (WITH BATTERY)	819 lbs	372 Kg
SHIPPED FULLY ASSEMBLED		

	SHORT HEAD (STANDARD)	LONG HEAD (OPTION)
A	15 1/8" [384 mm]	16 1/2" [420 mm]
B	20 5/8" [524 mm]	22 1/2" [572 mm]

FOR OTHER SPECIAL CONFIGURATIONS CONTACT HELITOWCART

PROPRIETARY AND CONFIDENTIAL

THE INFORMATION CONTAINED IN THIS DRAWING IS THE SOLE PROPERTY OF HELITOWCART Inc. ANY REPRODUCTION IN PART OR AS A WHOLE WITHOUT THE WRITTEN PERMISSION OF HELITOWCART Inc. IS PROHIBITED.



HELITOWCART.COM
INFO@HELITOWCART.COM
+1.418.561.4512

V650

UNIT : [mm]
in

Print Date: 2020-10-16